

THIS COPY IS PROVIDED ON A RESTRICTED BASIS AND IS NOT TO BE USED IN ANY WAY DETRIMENTAL TO THE INTERESTS OF PANDUIT CORP.

NOTES:

1. DIMENSIONS IN [ ] ARE IN MILLIMETERS.



PANDUIT PART NO.	MATERIAL	FACE COLOR	PKG. QTY.	THICKNESS	PRODUCT TYPE
C120X190A0T-22	GMH3	BLACK	500	.030 +/- .010	POLYESTER/ FOAM COMPONENT LABEL
C120X190A8T-22		YELLOW			
C120X190APT-22	GMH3-W	WHITE			
C120X190AST-22	GMH3	GREEN			
C120X190AWT-22		RED			

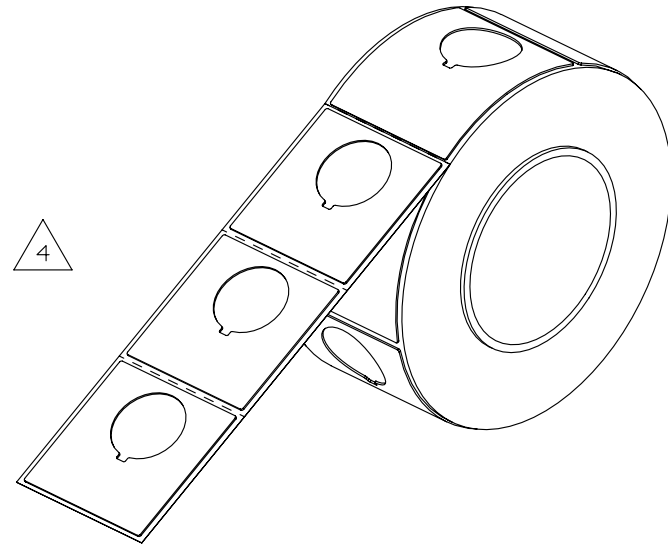
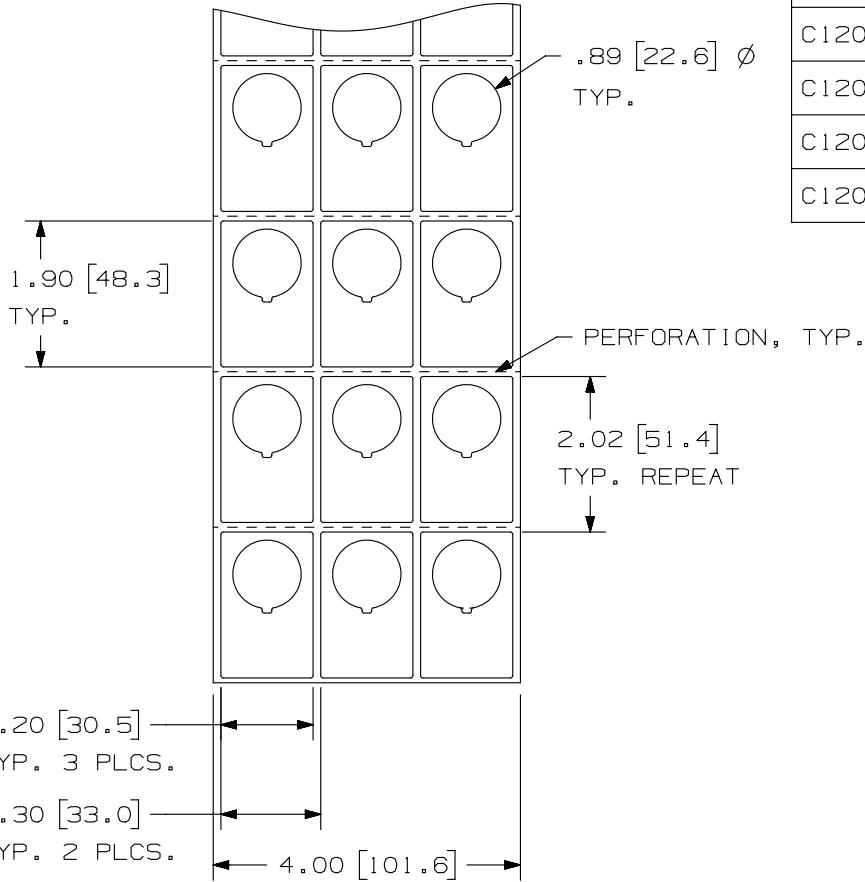

REV	DATE	BY	CHK	APR	DESCRIPTION	ECN
4	1/9/13	RVU	DAPE	SEWH	ADD material column and ISO view. Update part numbers sequence list.	GAECN00512
3	5/3/10	RVU	DAPE		TOL. SHOULD BE .12, .062, NOT .1, .050.	6036
2	1/30/09	RVU	DAPE		REMOVE "REPEAT" FROM THE LABEL SIZE. ADD DIM. PERF. VERTICAL. REMOVE C120X190AMT-22.	5592
1	1/14/08	RVU			VOID	
0	9/5/08	RVU	PTR		DRAWING RELEASE.	5537

TITLE						
<b>RAISED PANEL PUSH BUTTON LABELS</b> <b>C120X190A*T-22</b> CUSTOMER DRAWING						
ITEM REVISION NAME				100491BM/05		
DATASET FILE NAME				100491BM-DC-C10726/05E		
UNLESS OTHERWISE SPECIFIED, DIMENSIONAL TOLERANCES ARE: IN [ mm ]				<b>PANDUIT</b> <sup>TM</sup>  MATERIAL:  SEE TABLE		
.x ± .12 [ 3.05 ]      .xxx ± .025 [ .635 ] .xx ± .062 [ 1.57 ]      ANGLES ±						
THIRD ANGLE PROJECTION				DRAWING NUMBER: C10726		
DRAWN BY	DATE	CHK	SCALE	SHT 1 OF 1		SIZE
RVU	9/5/08	MSAD	NTS			A

D10100DA/12